

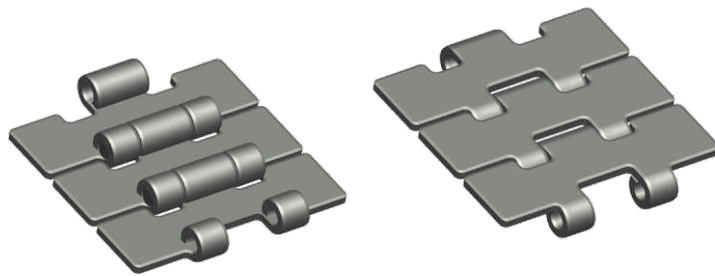

SP-512 SERIES



DIMENSION	mm	inch
P	25.4	1.00
M	42.3	1.67
L	6.30	0.25
H	12.8	0.50
E	6.35	0.25
T	3.10	0.12
G	1.60	0.06
D	44.0	1.73

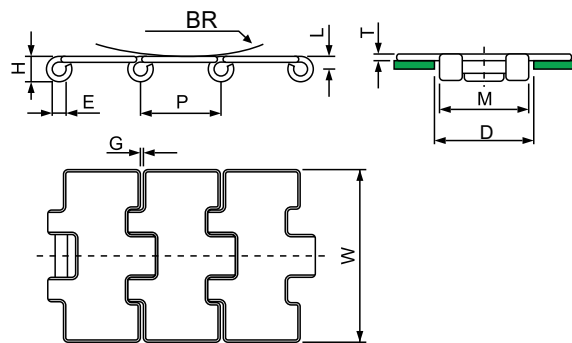

Plate Materials : Ferritic steel
Pin Material : Martensitic steel

SP-512 (Straight Running SS Mini Chain)

	Width W (mm)	Width W (inch)	Working Load (N)	Backflex Radius(BR) (mm)	Weight (kg/m)
SP-512 K250	63.5	2.50	5000	100	2.49

standard length : 80 pitches (10 feet - 3.048 m)



SP-512 SERIES ACCESSORIES

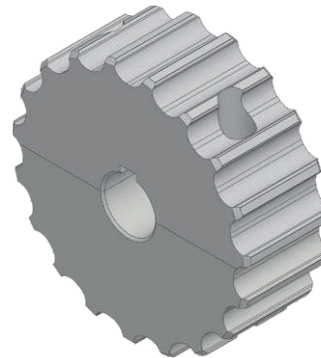
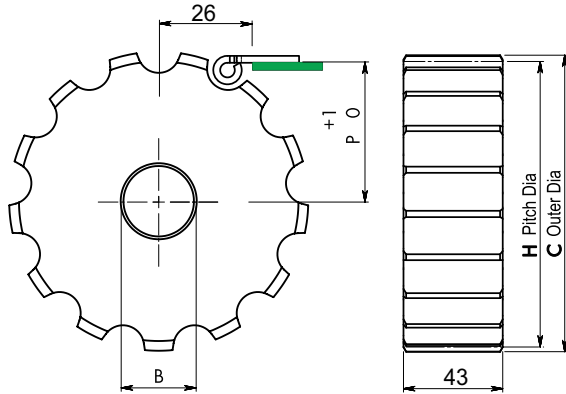

MATERIAL : POLYAMIDE

SP-812 (SPROCKET)

CODE	TEETH (Z)	C	H	P	M/C
SP-512 S 13	13	107.4	106.1	57.2	■
SP-512 S 15	15	123.9	122.2	65.2	■
SP-512 S 17	17	140.3	138.2	72.3	■
SP-512 S 19	19	156.6	154.3	80.4	■
SP-512 S 21	21	172.9	170.4	88.4	■
SP-512 S 23	23	189.2	186.5	96.5	■
SP-512 S 25	25	205.4	202.7	104.6	■

BORE (B) - Ø 25,30,35