

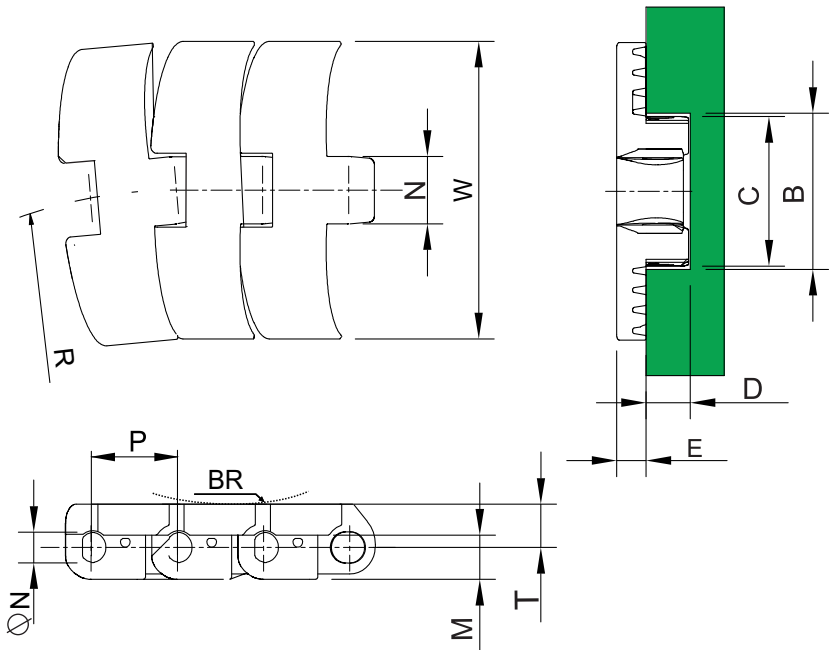

# SP-1060



DIMENSION	mm	inch
P	25.4	1.00
T	12.2	0.48
M	12.5	0.49
N	8.60	0.34
B	44.0	1.73
C	42.1	1.66
D	13.0	0.51
E	8.70	0.34

**Plate Materials :** Polyacetal  
**Pin Material :** Stainless steel

## SP-1060 (Flattop Magnetflex Chain)

	Width W (mm)	Width W (inch)	Working Load (N)	Sideflex Radius(R) (mm)	Backflex Radius(BR) (mm)	Weight (kg/m)
SP-1060	83.8	3.30	1900	500	130	1.68

standard length : 120 links (10 feet - 3.048 m)



## SP-1050 ACCESSORIES

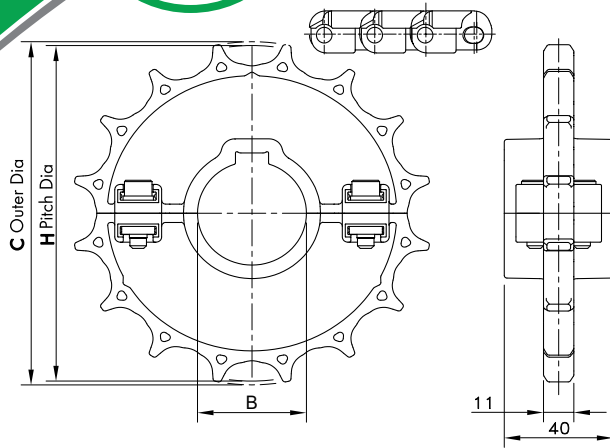

Materials : Polyamide

### SP-1050 (SPROCKET)

CODE	TEETH (Z)	C	H	MOULDED
SP-1050 S 16	16	130.9	130.2	■
SP-1050 S 18	18	146.8	146.3	■

BORE (B) -  $\varnothing$  30,40

For Plastic Chains Series : 1050, 1055, 1060