

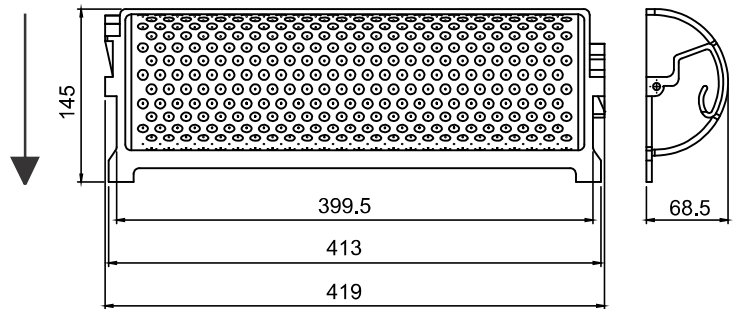

ELEVATING BUCKET

ELEVATING BUCKET(1.8L)

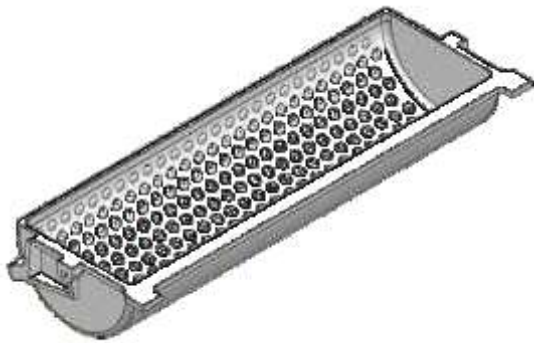

Part No. : SP - B 1.8L
 BUCKET MATERIAL : PP
 BUCKET COLOR : WHITE

ELEVATING BUCKET - 1.8L CHAIN

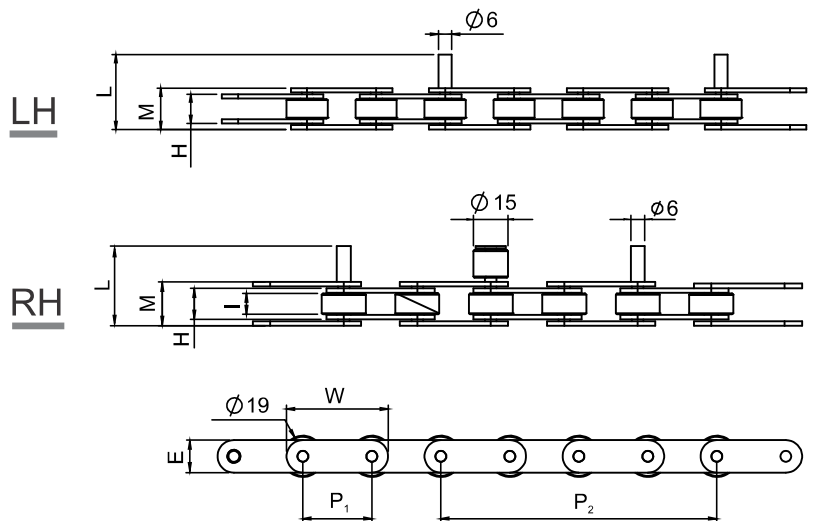
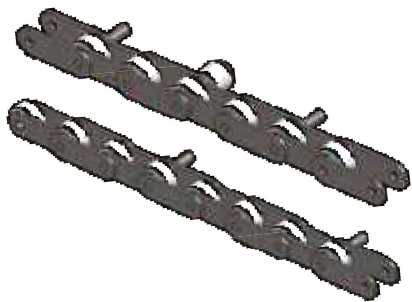

DIMENSION	mm	inch
P ₁	31.8	1.25
P ₂	127	5.00
W	46.8	1.84
L	34.5	1.36
M	19.0	0.75
H	13.5	0.53
E	15.0	0.59
I	9.00	0.35

Roller Material : PA 6
 Plate Material : Austenitic steel



ELEVATING BUCKET

ELEVATING BUCKET(2.8L)

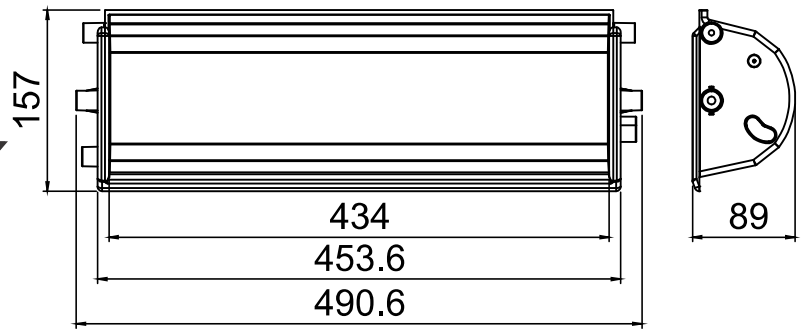

Part No. : SP - B 2.8L
 BUCKET MATERIAL : ABS/PP
 BUCKET COLOR : BLUE/WHITE

ELEVATING BUCKET - 2.8L CHAIN

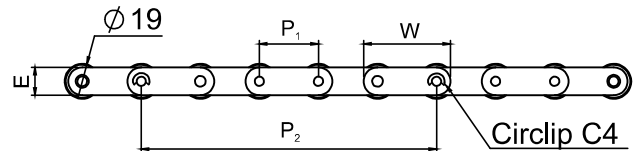
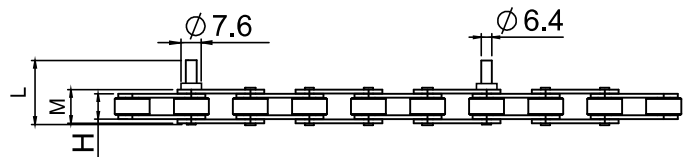
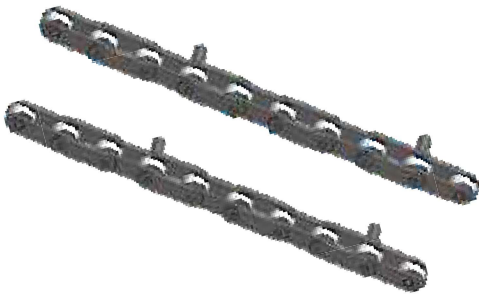

Roller Material : Steel
Plate Material : Austenitic steel

DIMENSION	mm	inch
P ₁	31.8	1.25
P ₂	158.8	6.25
W	46.8	1.84
L	44.0	1.73
M	18.0	0.71
H	13.6	0.54
E	15.0	0.59

2.8L BUCKET - SUPPORT SPROCKET

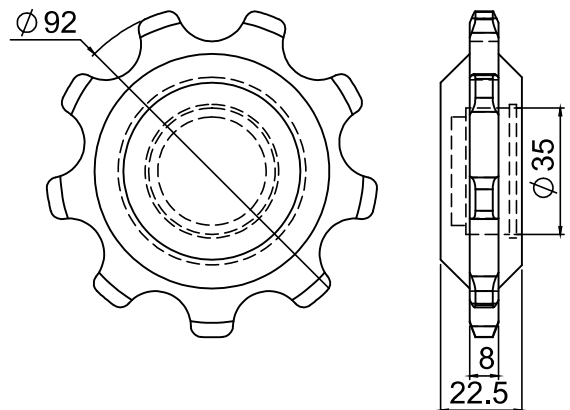
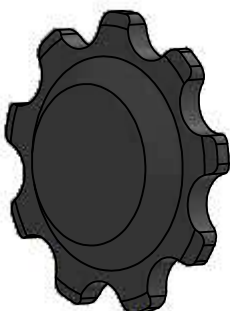



ELEVATING BUCKET ACCESSORIES

ELEVATING BUCKET (SPROCKET)

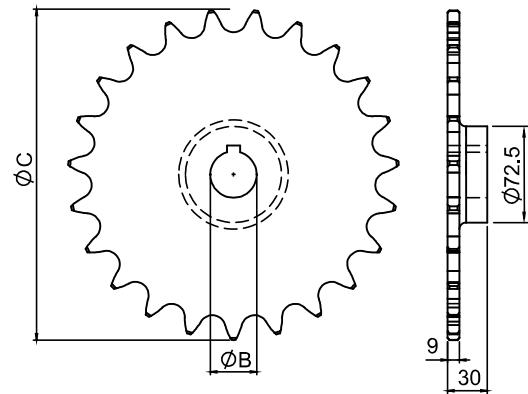

TEETH (Z)	C	M/C
23	249.5	■
30	312	■

BORE (B) - $\varnothing 30,35,40$

ELEVATING BUCKET (CHAIN GUIDE)

